

TEKENINGENLIJST

BLAD	SCHAAL	DATUM	LAATSTE WIJZIGING	STATUS
0.01	1:20	24-02-2020		definitief
0.02	1:20	24-02-2020		definitief
0.03	1:20	24-02-2020		definitief
0.04	1:20	24-02-2020		definitief
0.05	1:20	24-02-2020		definitief
1.01	1:20	24-02-2020		definitief
1.02	1:20	24-02-2020		definitief
1.03	1:20	24-02-2020		definitief
1.04	1:20	24-02-2020	a: 25-01-2022	definitief
1.05	1:20	24-02-2020	mvr	definitief
2.01	1:20	24-02-2020		definitief
2.02	1:20	24-02-2020		definitief
2.03	1:20	24-02-2020		definitief
3.01	1:20	24-02-2020		definitief
3.02	1:20	24-02-2020		definitief
3.03	1:20	24-02-2020		definitief
3.04	1:20	24-02-2020		definitief
3.05	1:20	24-02-2020		definitief
3.06	1:20	24-02-2020		definitief
3.07	1:20	24-02-2020		definitief
4.01	1:20	24-02-2020		definitief
4.02	1:20	24-02-2020		definitief
4.03	1:20	24-02-2020		definitief
4.04	1:20	24-02-2020		definitief
PD-01	1:10	24-02-2020		definitief

details begane grond t/m dakvloer

WIJZIGINGEN

WIJZ	WIJZIGINGSDATUM	OMSCHRIJVING
a	25-01-2022	mvr opmerkingen Trebbe verwerkt



62 woningen Nieuwegein Hoeverijk

ONDERDEEL
 details begane grond t/m dakvloer
 4 - laags woning
OPDRACHTGEVER LUCASSEN
 Trebbe Wonen B.V.

PROJECT NR.
 19-289

FASE
 definitief ontwerp

SCHAAL
 1:20

CONSTRUCTEUR
 mgl

TEKENING NR.
 DET-000

STATUS
 definitief

TEKENAAR
 mvr

DATUM
 24-02-2020

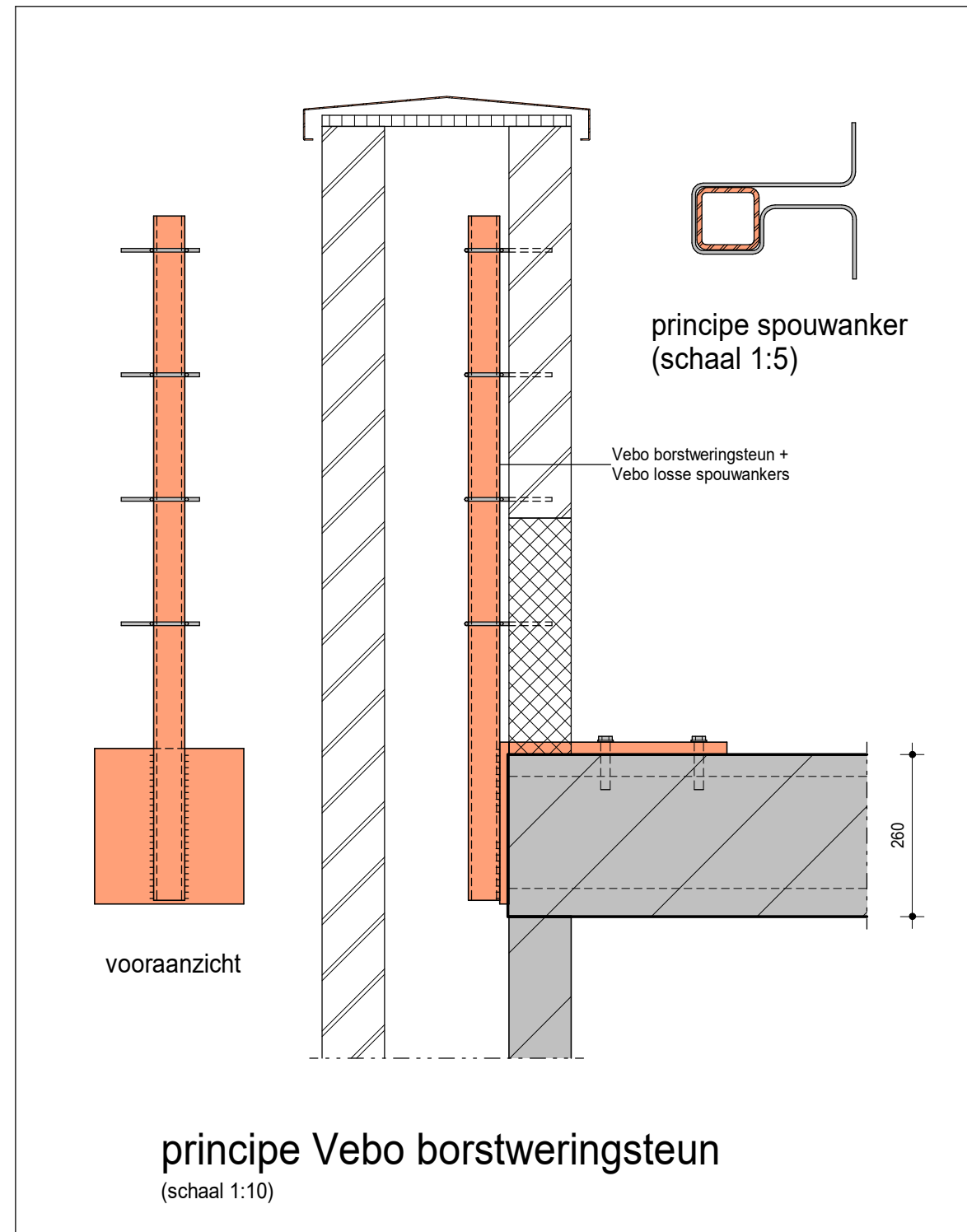

ONDERDEEL
principedetails

LUCASSEN BOUWCONSTRUCTIES BV ■ JAN TINBERGENSTRAAT 103

62 woningen Nieuwegein Hoeverijk

PROJECT NR.
19-289

STATUS
definitief

TEKENING NR.
PD-01

SCHAAL
1:10

DATUM
24-02-2020

WIJZ. DATUM

POSTBUS 748 ■ 7550 AS HENGELO ■ TEL (074) 255 68 00 ■ FAX (074) 255 68 11 ■ INFO@LUCASSEN-BC.NL

BIM 360://Nieuwegein - Blok west Hoeverijk/blok01-02_LBC_constructie.rvt

A3: 420x297

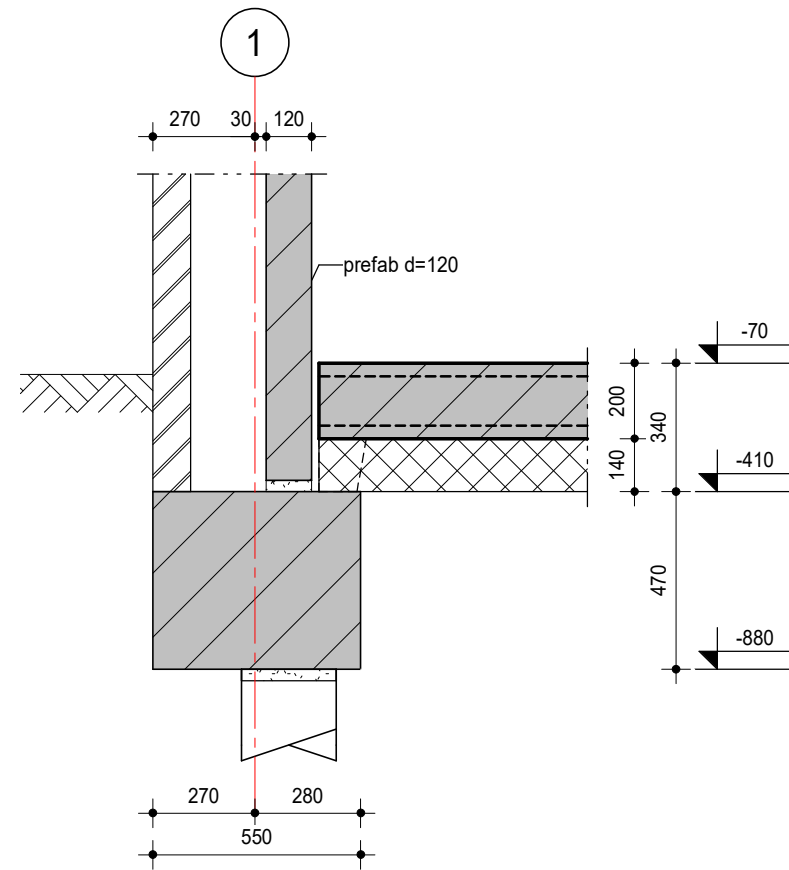

detail 0.01



ONDERDEEL
detail begane grondvloer

62 woningen Nieuwegein Hoeverijk

PROJECT NR. 19-289	TEKENING NR. 0.01	DATUM 24-02-2020
STATUS definitief	SCHAAL 1:20	WIJZ. DATUM

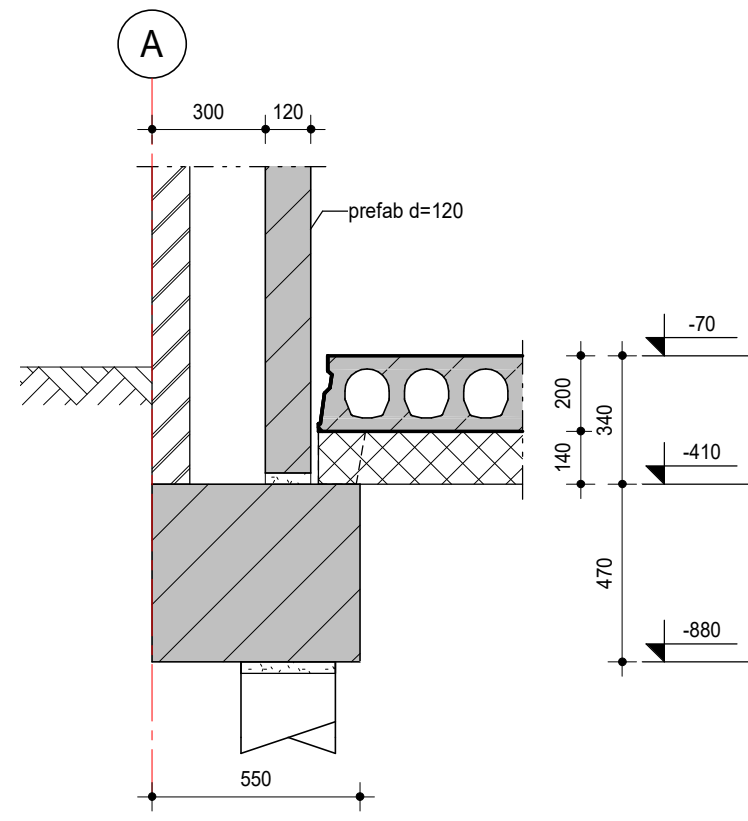

detail 0.03



ONDERDEEL
details begane grondvloer

62 woningen Nieuwegein Hoeverijk

PROJECT NR. 19-289	TEKENING NR. 0.03	DATUM 24-02-2020
STATUS definitief	SCHAAL 1:20	WIJZ. DATUM

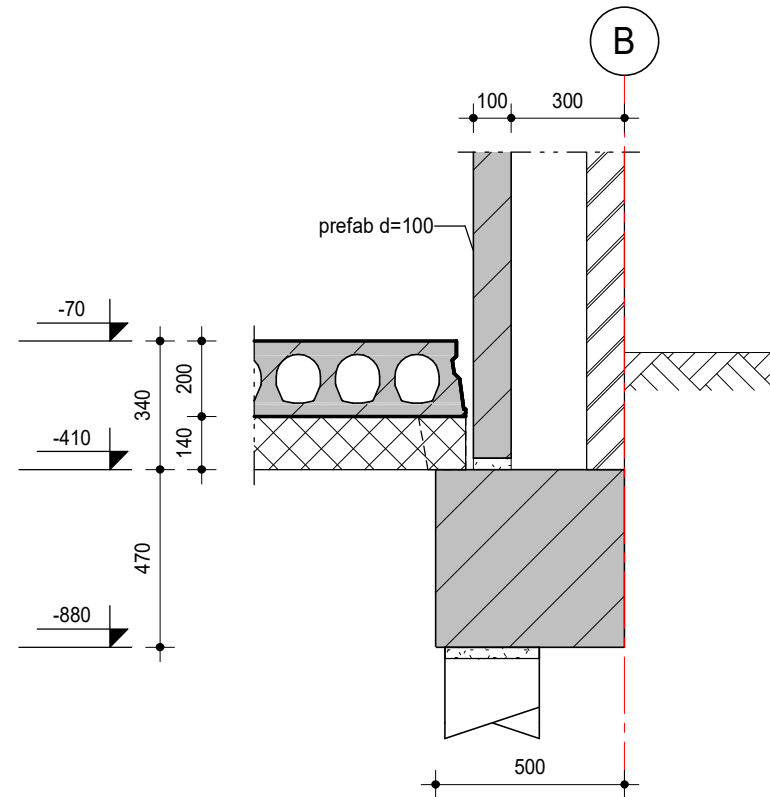

detail 0.04



ONDERDEEL
details begane grondvloer

62 woningen Nieuwegein Hoeverijk

PROJECT NR. 19-289	TEKENING NR. 0.04	DATUM 24-02-2020
STATUS definitief	SCHAAL 1:20	WIJZ. DATUM

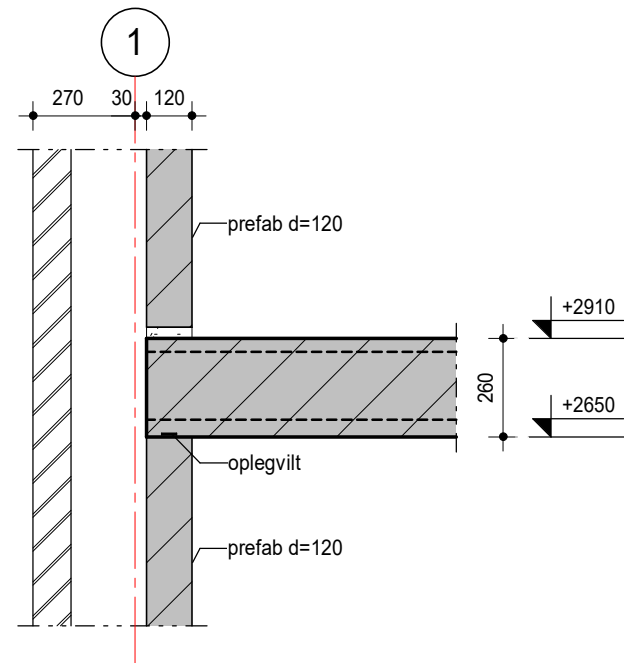

detail 1.01



ONDERDEEL
details 1e verdiepingvloer

62 woningen Nieuwegein Hoeverijk

PROJECT NR. 19-289	TEKENING NR. 1.01	DATUM 24-02-2020
STATUS definitief	SCHAAL 1:20	WIJZ. DATUM

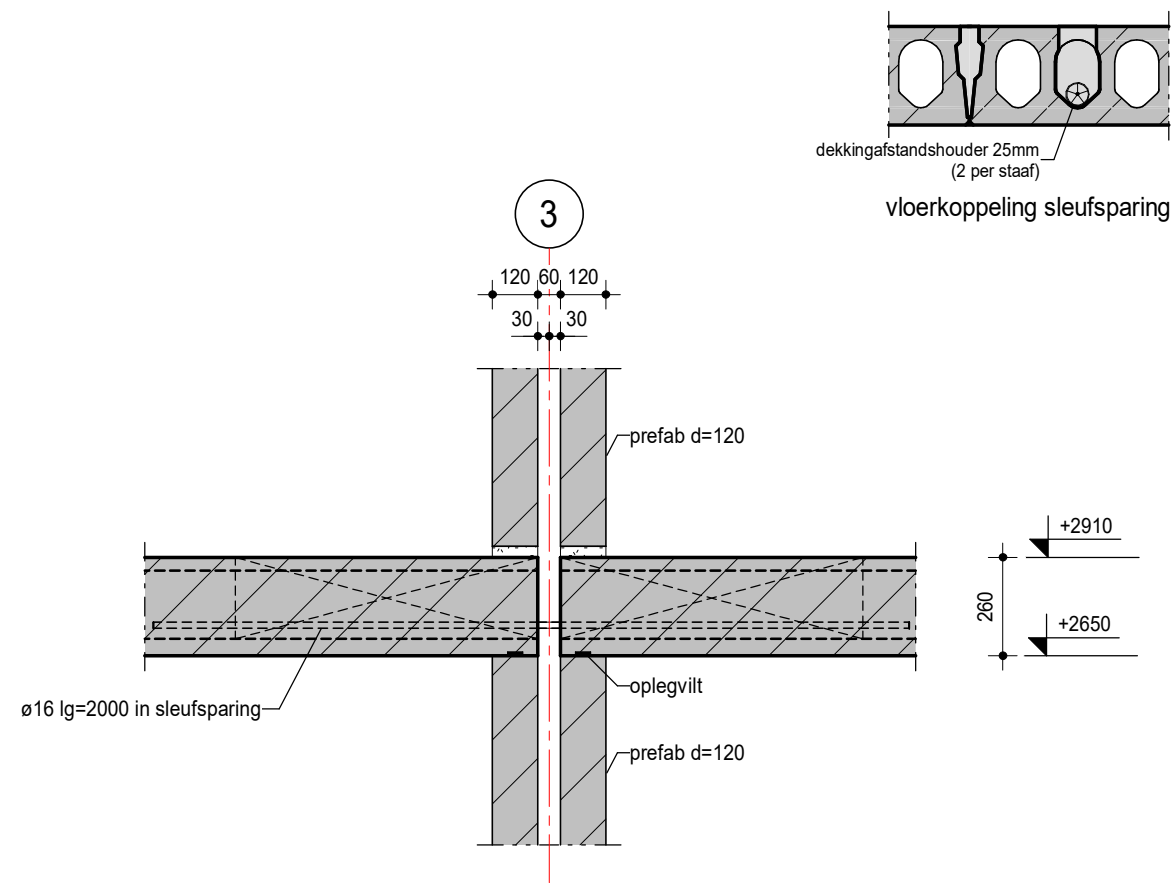

detail 1.02



ONDERDEEL
details 1e verdiepingvloer

62 woningen Nieuwegein Hoeverijk

PROJECT NR. 19-289	TEKENING NR. 1.02	DATUM 24-02-2020
STATUS definitief	SCHAAL 1:20	WIJZ. DATUM

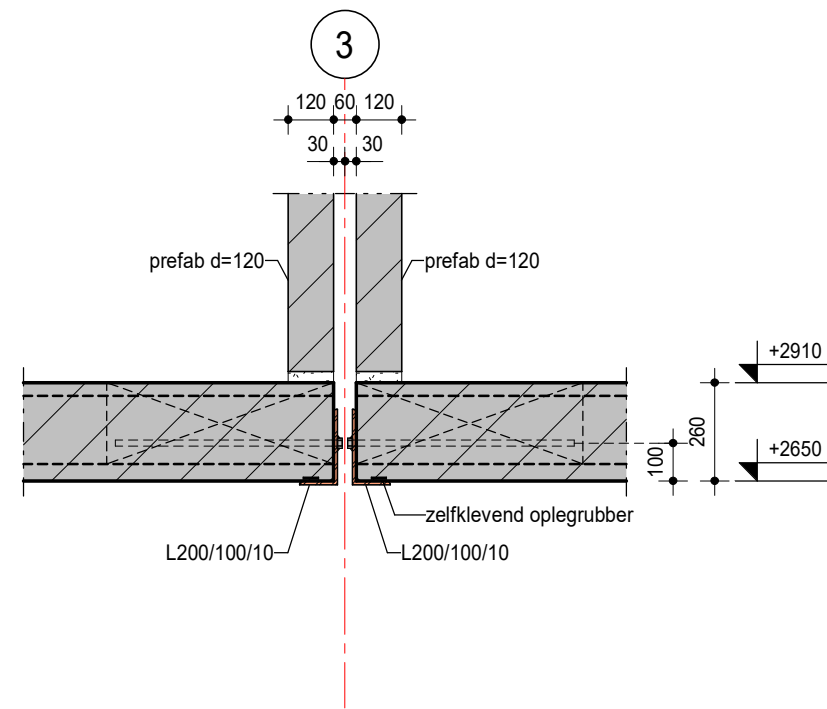

detail 1.03



ONDERDEEL
details 1e verdiepingsvloer

62 woningen Nieuwegein Hoeverijk

PROJECT NR. 19-289	TEKENING NR. 1.03	DATUM 24-02-2020
STATUS definitief	SCHAAL 1:20	WIJZ. DATUM

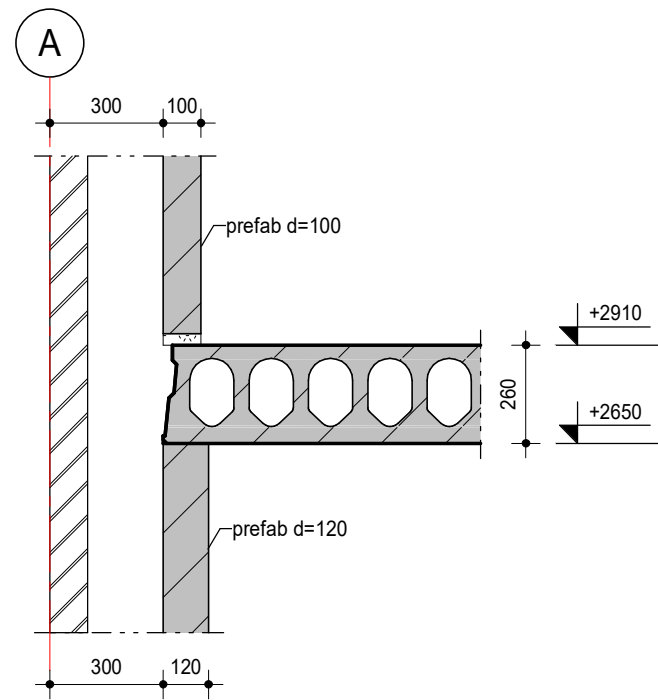

detail 1.04



■ ONDERDEEL
details 1e verdiepingvloer

62 woningen Nieuwegein Hoeverijk

■ PROJECT NR. 19-289	■ TEKENING NR. 1.04	■ DATUM 24-02-2020
■ STATUS definitief	■ SCHAAAL 1:20	■ WIJZ. DATUM a : 25-01-2022 mvr

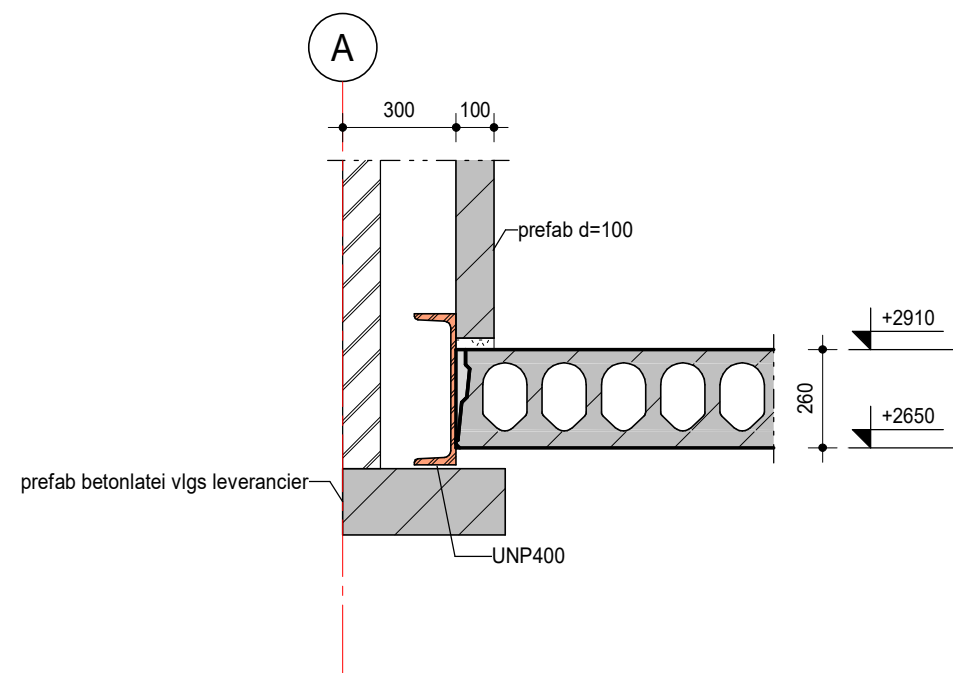

detail 1.05



ONDERDEEL
details 1e verdiepingvloer

62 woningen Nieuwegein Hoeverijk

PROJECT NR. 19-289	TEKENING NR. 1.05	DATUM 24-02-2020
STATUS definitief	SCHAAL 1:20	WIJZ. DATUM

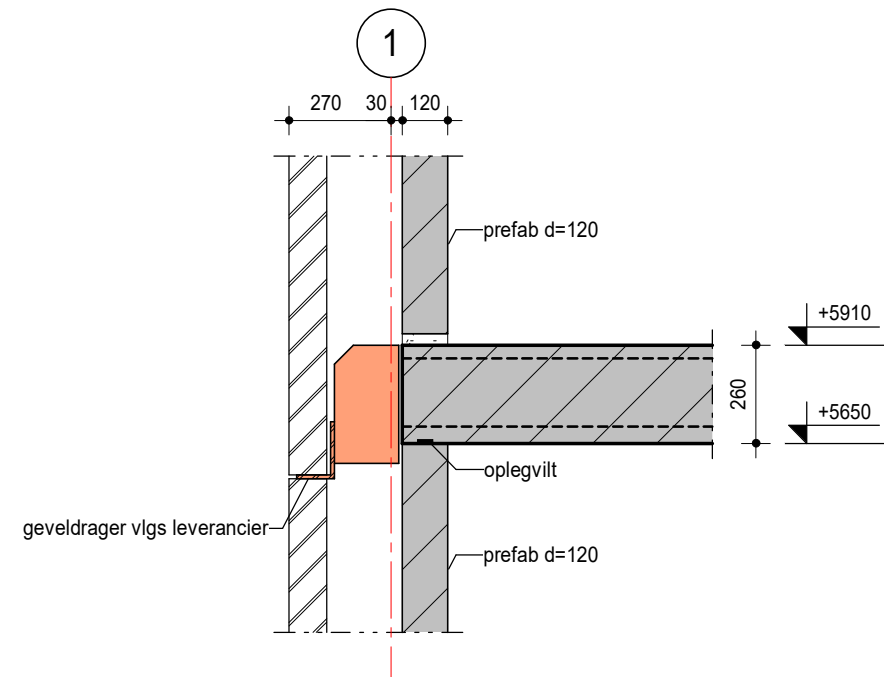

detail 2.01



ONDERDEEL
details 2e verdiepingvloer

62 woningen Nieuwegein Hoeverijk

PROJECT NR. 19-289	TEKENING NR. 2.01	DATUM 24-02-2020
STATUS definitief	SCHAAL 1:20	WIJZ. DATUM

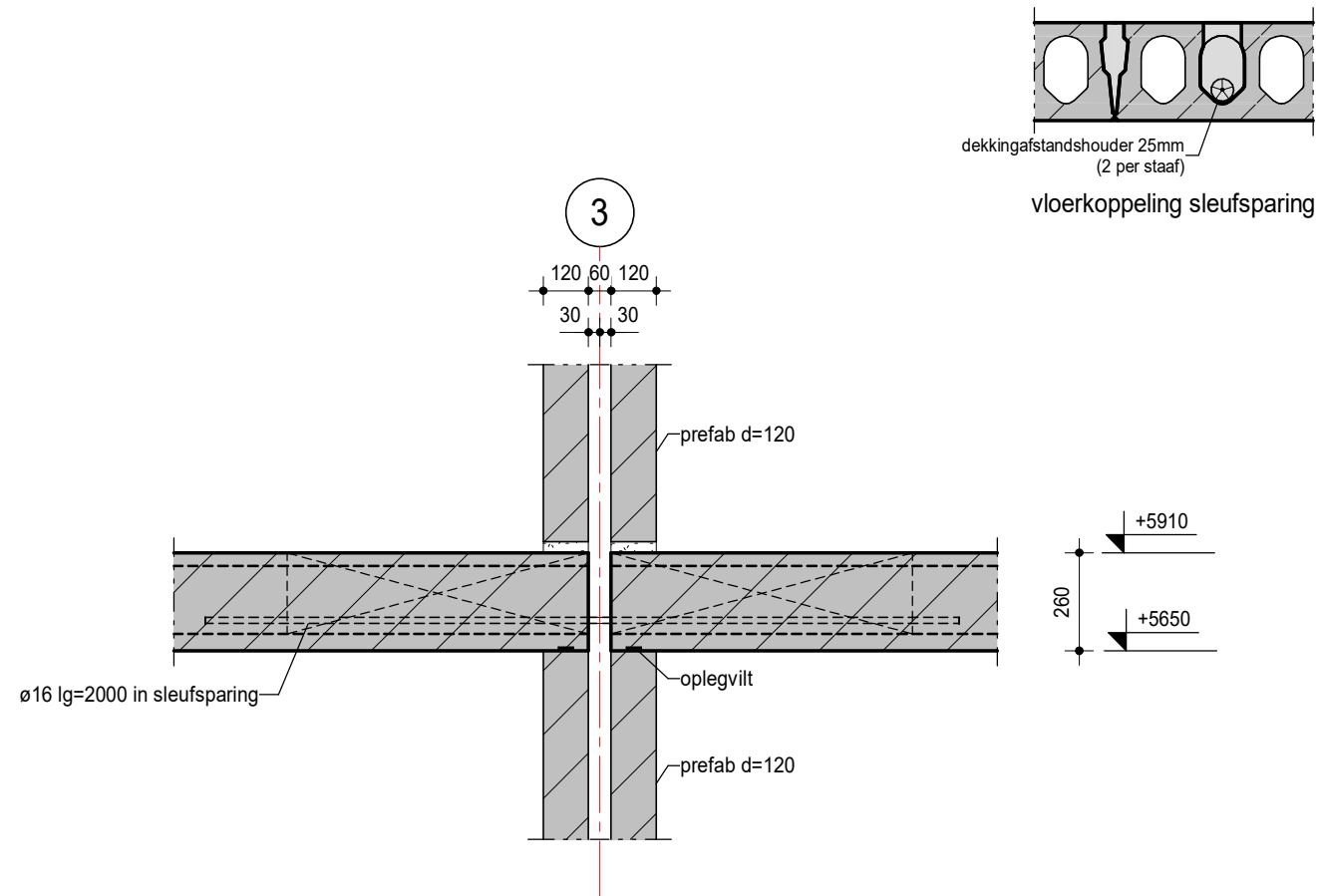

detail 2.02



ONDERDEEL
details 2e verdiepingvloer

62 woningen Nieuwegein Hoeverijk

PROJECT NR. 19-289	TEKENING NR. 2.02	DATUM 24-02-2020
STATUS definitief	SCHAAL 1:20	WIJZ. DATUM

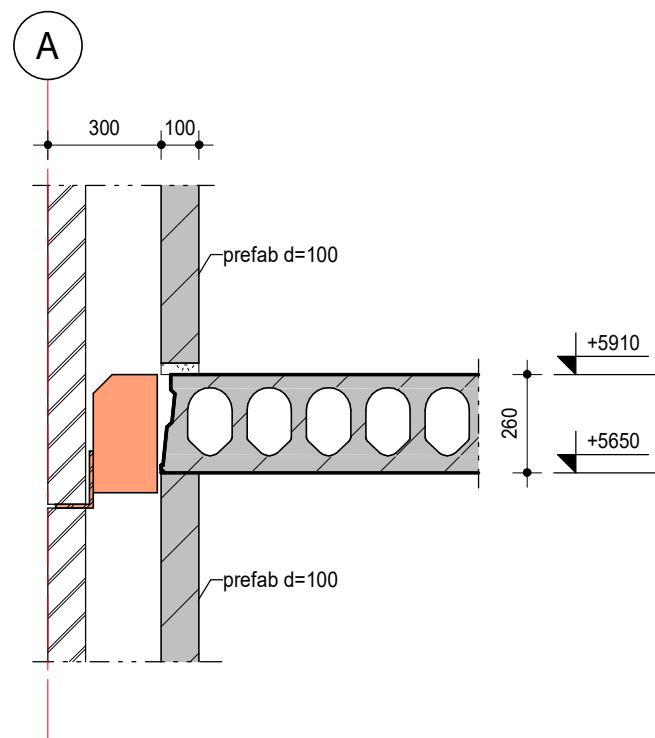

detail 2.03



ONDERDEEL
details 2e verdiepingvloer

62 woningen Nieuwegein Hoeverijk

PROJECT NR. 19-289	TEKENING NR. 2.03	DATUM 24-02-2020
STATUS definitief	SCHAAL 1:20	WIJZ. DATUM

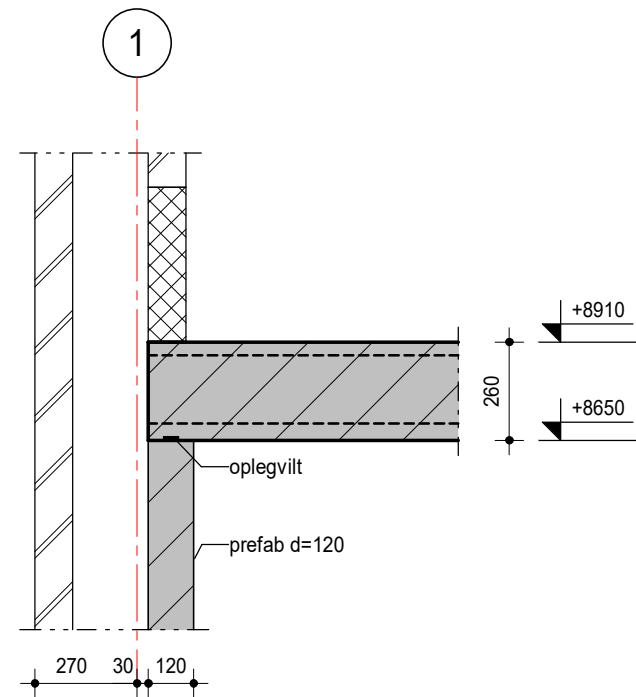

detail 3.01



ONDERDEEL
details 3e verdiepingvloer

62 woningen Nieuwegein Hoeverijk

PROJECT NR. 19-289	TEKENING NR. 3.01	DATUM 24-02-2020
STATUS definitief	SCHAAL 1:20	WIJZ. DATUM

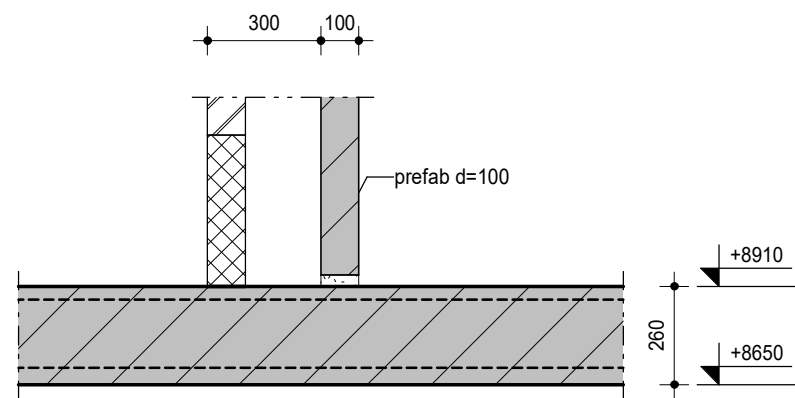

detail 3.02



■ ONDERDEEL
details 3e verdiepingvloer

62 woningen Nieuwegein Hoeverijk

■ PROJECT NR. 19-289	■ TEKENING NR. 3.02	■ DATUM 24-02-2020
■ STATUS definitief	■ SCHAAAL 1:20	■ WIJZ. DATUM

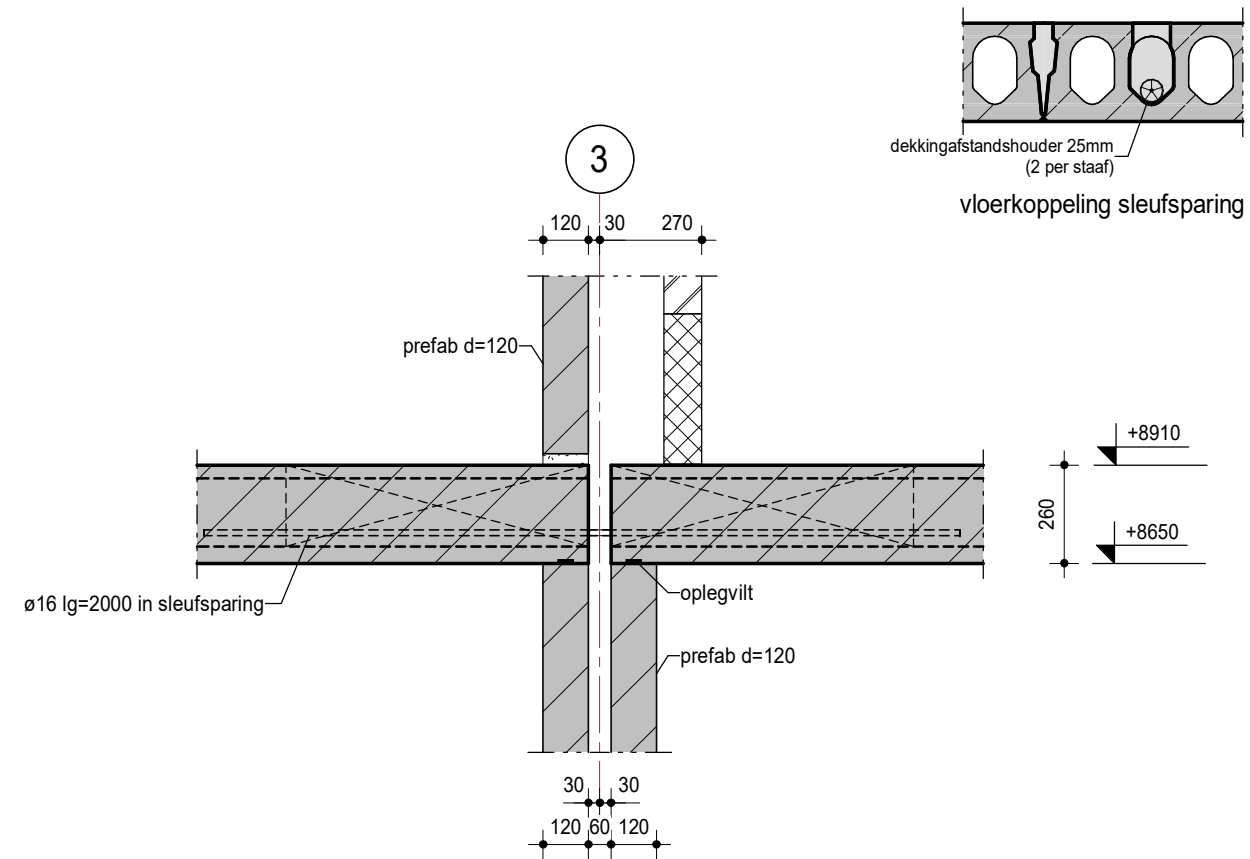

detail 3.03



ONDERDEEL
details 3e verdiepingvloer

62 woningen Nieuwegein Hoeverijk

PROJECT NR. 19-289	TEKENING NR. 3.03	DATUM 24-02-2020
STATUS definitief	SCHAAL 1:20	WIJZ. DATUM

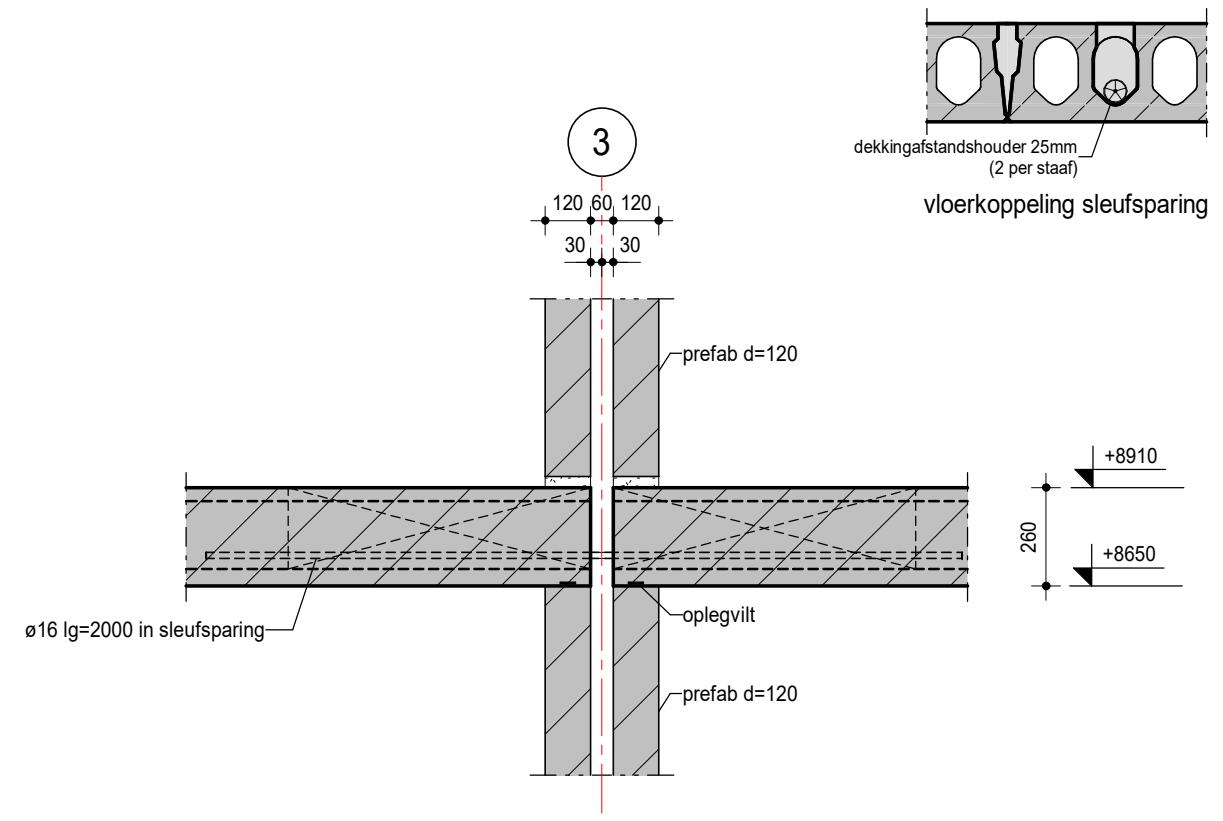

detail 3.04



■ ONDERDEEL
details 3e verdiepingvloer

62 woningen Nieuwegein Hoeverijk

■ PROJECT NR. 19-289	■ TEKENING NR. 3.04	■ DATUM 24-02-2020
■ STATUS definitief	■ SCHAAL 1:20	■ WIJZ. DATUM

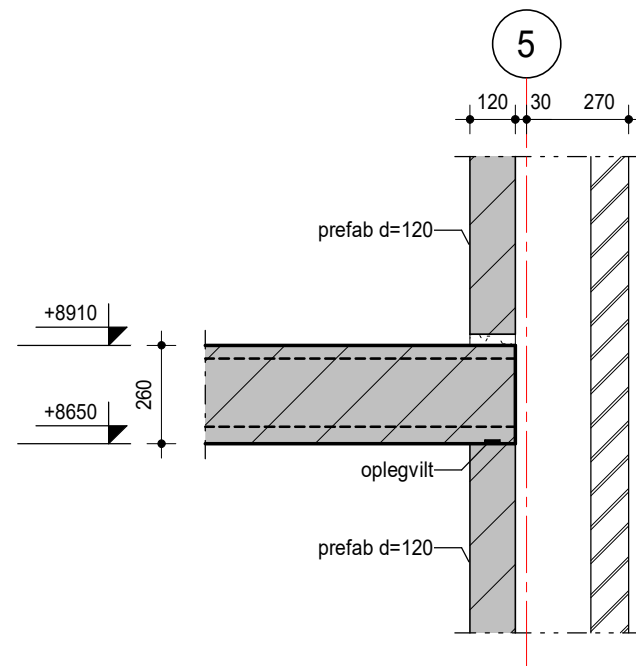

detail 3.05



ONDERDEEL
details 3e verdiepingvloer

62 woningen Nieuwegein Hoeverijk

PROJECT NR. 19-289	TEKENING NR. 3.05	DATUM 24-02-2020
STATUS definitief	SCHAAL 1:20	WIJZ. DATUM

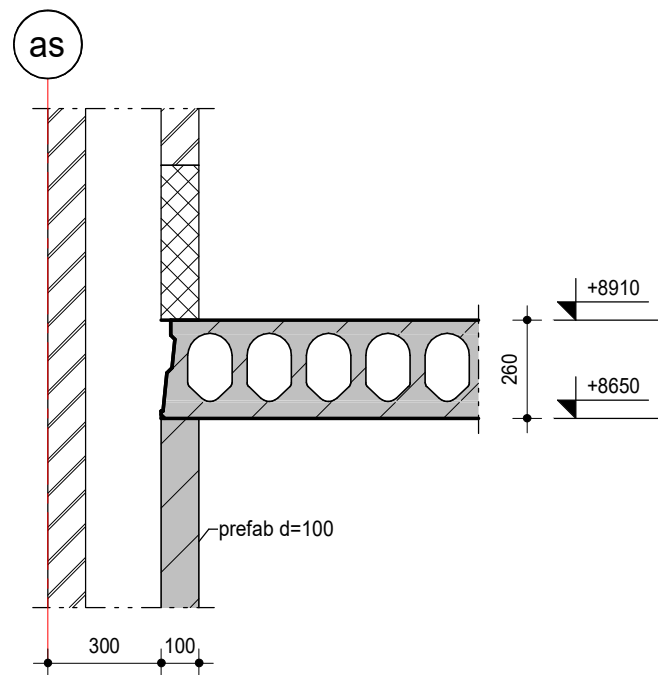

detail 3.06



ONDERDEEL
details 3e verdiepingvloer

62 woningen Nieuwegein Hoeverijk

PROJECT NR. 19-289	TEKENING NR. 3.06	DATUM 24-02-2020
STATUS definitief	SCHAAL 1:20	WIJZ. DATUM

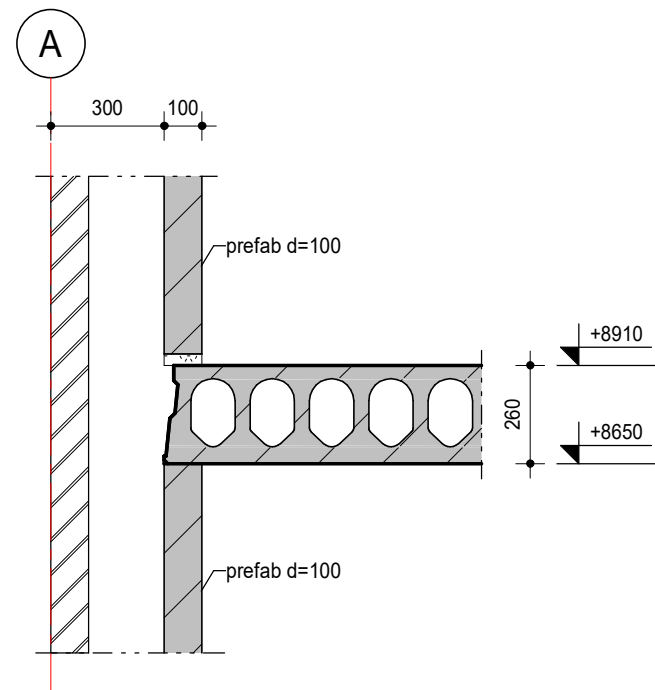

detail 3.07



■ ONDERDEEL
details 3e verdiepingvloer

62 woningen Nieuwegein Hoeverijk

■ PROJECT NR. 19-289	■ TEKENING NR. 3.07	■ DATUM 24-02-2020
■ STATUS definitief	■ SCHAAAL 1:20	■ WIJZ. DATUM

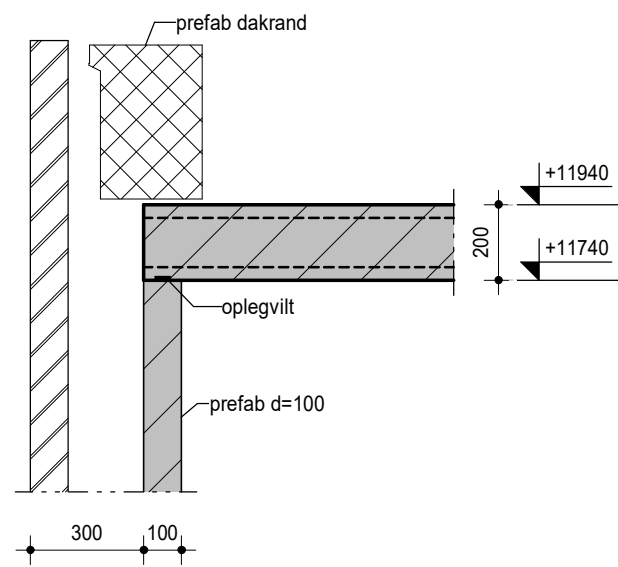

detail 4.01



ONDERDEEL
details dakvloer

LUCASSEN BOUWCONSTRUCTIES BV ■ JAN TINBERGENSTRAAT 103

62 woningen Nieuwegein Hoeverijk

PROJECT NR. 19-289	TEKENING NR. 4.01	DATUM 24-02-2020
STATUS definitief	SCHAAL 1:20	WIJZ. DATUM

POSTBUS 748 ■ 7550 AS HENGELO ■ TEL (074) 255 68 00 ■ FAX (074) 255 68 11 ■ INFO@LUCASSEN-BC.NL

BIM 360://Nieuwegein - Blok west Hoeverijk/blok01-02_LBC_constructie.rvt

A3: 420x297

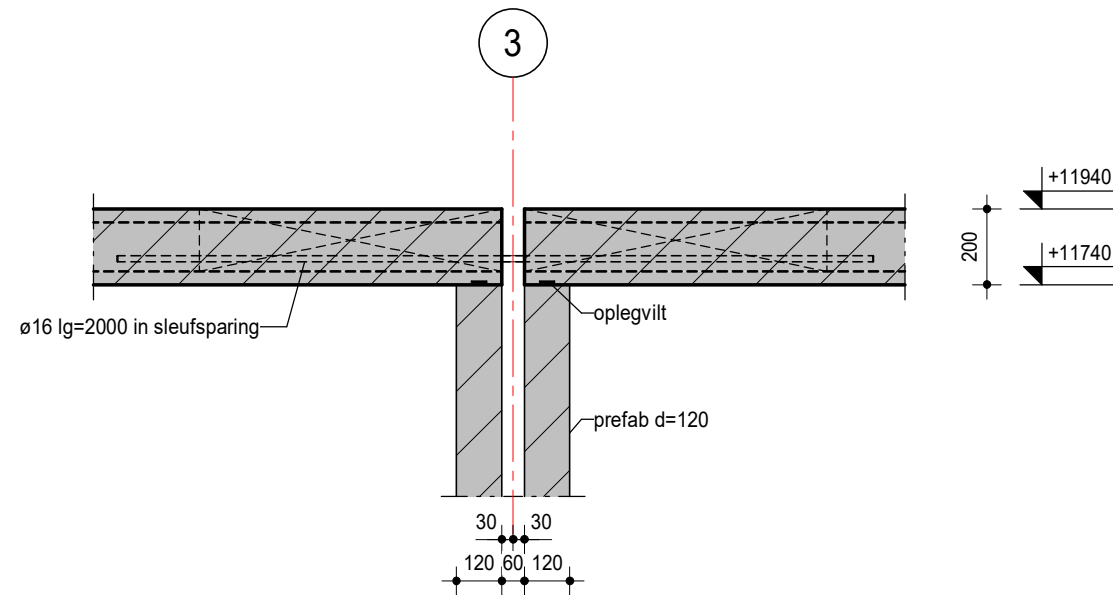
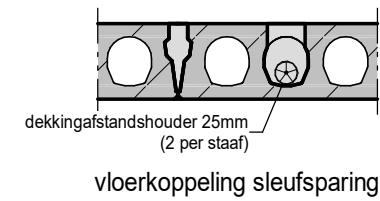

detail 4.02



ONDERDEEL
details dakvloer

62 woningen Nieuwegein Hoeverijk

PROJECT NR. 19-289	TEKENING NR. 4.02	DATUM 24-02-2020
STATUS definitief	SCHAAL 1:20	WIJZ. DATUM

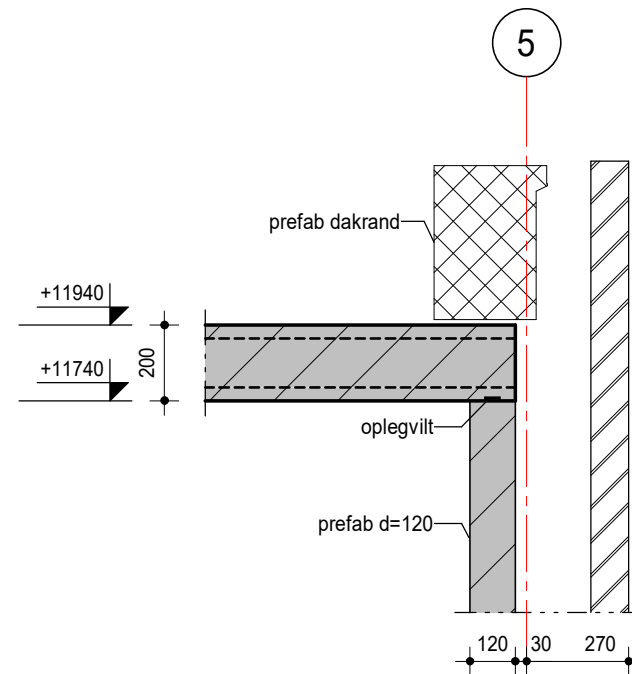

detail 4.03



ONDERDEEL
details dakvloer

62 woningen Nieuwegein Hoeverijk

PROJECT NR. 19-289	TEKENING NR. 4.03	DATUM 24-02-2020
STATUS definitief	SCHAAL 1:20	WIJZ. DATUM

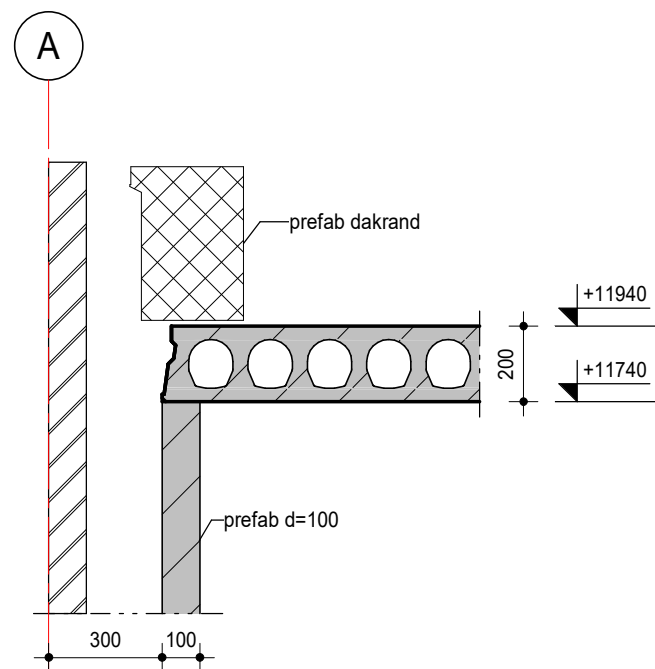

detail 4.04



ONDERDEEL
details dakvloer

62 woningen Nieuwegein Hoeverijk

PROJECT NR. 19-289	TEKENING NR. 4.04	DATUM 24-02-2020
STATUS definitief	SCHAAL 1:20	WIJZ. DATUM